

MATHEMATICAL MODELING TO EFFICIENT PROTOCOLS TO CONTROL GLIOMA GROWTH

J.R. BRANCO, J.A. FERREIRA AND P. DE OLIVEIRA

ABSTRACT: In this paper we propose a mathematical model to describe the evolution of glioma cells taking into account the viscoelastic properties of brain tissue. The mathematical model is established considering that the glioma cells are of two phenotypes: migratory and proliferative. The evolution of the migratory cells is described by a diffusion-reaction equation of non Fickian type deduced considering a mass conservation law with a non Fickian migratory mass flux. The evolution of the proliferative cells is described by a reaction equation. A stability analysis that leads to the design of efficient protocols is presented. Numerical simulations that illustrate the behaviour of the mathematical model are included.

Keywords: Glioma, Viscoelastic behavior, Chemotherapy, Protocols, Numerical simulation.

1. Introduction

Cancer is a complex disease which leads to the uncontrolled growth of abnormal cells, destruction of normal tissues and invasion of vital organs. There are different stages of tumor development with varying duration, starting from genetic changes at the cell level and finishing with detachment of metastasis and invasion. Tumor cell transport and proliferation are the main contributors to the malignant dissemination ([Swanson et al.(2003)]).

Extensive research has been done to model cancerous growth, specially on solid tumors, in which growth primarily comes from cellular proliferation. It is far beyond the aim of the present paper to list exhaustively the many significant contribution in the topic. References [Fedotov et al.(2007)], [Giese et al.(1996)], [Habib et al.(2003)], [Harpold et al.(2007)], [Murray(2002)], [Swanson et al.(2000)], [Swanson et al.(2003)] and the references therein represent some of these contributions.

Gliomas are diffusive and highly invasive brain tumors accounting for about 50% of all primary brain tumors and, unfortunately, the prognosis for patients with gliomas is very poor. Median untreated survival time for high grade gliomas ranges from 6 months to 1 year and even lower grade gliomas

can rarely be cured. Theorists and experimentalists believe that inefficiency of treatments results from the high mobility of glioma cells. Additionally gliomas can exhibit very high proliferation rates.

The understanding of malignant glioma growth still very less complete, mostly because gliomas proliferate as solid tumors and invade the surrounding brain parenchyma actively. Proliferation and specially migration of gliomas represent a very challenging problem from a mathematical viewpoint.

Cancer research has been a fertile ground for mathematical modeling, beginning with the early concept of simple exponential growth of solid tumors doubling at a constant rate. The introduction of logistic or gompertzian growth (there is increased doubling time and decreased growth fraction as a function of time) allowed to slow the growth in the later stages. With the recognition that tumor cells might spread outside the grossly visible mass, invading locally and metastizing distantly, and that some cells die during the development process, the mathematical concepts necessarily became more complex than those used in the original simple models for solid tumors.

The initial answer to the question of how to measure the growth of an infiltrating glioma was provided by Murray in the early 90s ([Murray(2002)]). He formulated the problem as a conservation law where the rate of change of tumor's cell population results from mobility and net proliferation of cells. An equation of type

$$\frac{\partial c}{\partial t} + \nabla \cdot J_F = f(c) \text{ in } \Omega \times (0, \infty) \quad (1)$$

was used, where $\Omega \subset \mathbb{R}^n, n = 1, 2, 3$, is the glioma domain, $c(x, t)$ denotes the tumor cell density at location x and time t , $f(c)$ denotes net proliferation of tumor cells, and ∇ defines the spatial gradient operator. Under the assumption of the classical Fick's law for the mass flux J_F

$$J_F = -\tilde{D} \nabla c, \quad (2)$$

where \tilde{D} is the diffusion tensor, equation (1) can be written as

$$\frac{\partial c}{\partial t} = \nabla \cdot (\tilde{D} \nabla c) + f(c) \text{ in } \Omega \times (0, \infty). \quad (3)$$

The mathematical model is complemented by boundary conditions which impose no migration of cells beyond the brain boundary, that is,

$$J_F \cdot \eta = 0,$$

on the boundary, where η denotes the exterior unit normal to the brain region, and by initial conditions $c(x, 0) = c_0(x)$, $x \in \Omega$, where c_0 defines the initial spatial distribution of malignant cells.

Tumor growth is generally assumed to be exponential, so the cell growth term is given by $f(c) = \rho c$, where the net proliferation rate ρ is constant. Logistic and gompertzian growths have been also considered but found to be unnecessary in the time frames considered for gliomas development ([Harpold et al.(2007)]). To apply the modeling approach to specific patients, a more realistic look at the brain geometry and structure was necessary. Swanson *et al.* introduced in [Swanson et al.(2000)] the complex geometry of the brain and allowed diffusion to be a function of the spatial variable to reflect the observation that glioma cells exhibit higher motility in the white matter than in the grey matter.

The partial differential equation (3), of parabolic type, was established combining the mass conservation law (1) with Fick's law (2) for mass flux. It is well known that, in this case, if a sudden change on the cell concentration takes place somewhere in the space, it will be felt instantaneously everywhere. This means that Fickian approach gives rise to infinite speed of propagation which is not physically observable. To avoid the limitation of Fickian models an hyperbolic correction has been proposed in different contexts (see [Edwards et al.(1995b)], [Joseph et al.(1989)], [Fedotov(1998)], [Fedotov(1999)], [Hassanizadeh(1996)], [Neuman(2009)] and the references cited in these papers).

It is accepted by the biomedical research community that biochemical and biophysical properties of the brain tissue, namely of the extracellular matrix (ECM), are key factors in the proliferation and migration of glioma cells. The aggressiveness of the gliomas is determined by its unique pattern of interaction with ECM. Experimental studies show that the mechanical properties of ECM are regularization factors in the evolution of several cell types in particular glioma cells ([Engler et al.(2006)], [Engler et al.(2007)], [Lo et al.(2002)], [Tilghman et al.(2010)], [Ulrich et al.(2009)]). In fact it was observed that the growth, differentiation and functionalities of glioma cells are determined by the stiffness of the ECM. These observations are explained by the fact that extracellular matrix stiffness induces complex biochemical phenomena that depend on the type of diffusive cells and microenvironment properties which are not yet clarified. The complete understanding of such complex biochemical effect can be used to develop tumor treatments

based on the characteristics of the mechanical milieu where the cancer cells move.

The aim of the present paper is to study the influence of these properties on glioma growth and treatment. To this end we establish of a class of non Fickian models that take into account the viscoelastic behavior of the brain tissue. The mathematical model that we consider is defined in a simple geometry. To apply the modeling approach to specific patients, a more realistic look at the brain geometry and structure is necessary. In this case we can follow [Swanson et al.(2000)], where, for a Fickian model, a complex geometry of the brain was considered as well as a space dependent diffusion coefficient were taken into account to reflect the observation that glioma cells exhibit higher motility in the white matter than in grey matter ([Giese et al.(1996)]).

Finally we observe that the most popular treatments used to combat gliomas are chemotherapy and radiotherapy. Some mathematical models that describe the effect of these treatments were proposed in the literature. Without being exhaustive we mention [Laperriere et al.(2002)], [Rockne et al.(2009)] and [Tracqui et al.(1995)]. Chemotherapy involves the use of drugs to disrupt the cell cycle and to block proliferation. The success of chemotherapy agents varies widely, depending on cell type and the type of drug being used. The effectiveness of a particular drug depends on the concentration of drug reaching the tumor, the duration of exposure and the sensitivity of the tumor cells to the drug.

Tracqui *et al.* in [Tracqui et al.(1995)] incorporated chemotherapy by introducing cell death as a loss term. If $G(t)$ defines the rate of cells death then, assuming a loss proportional to the tumour cells density, equation (3) is replaced by

$$\frac{\partial c}{\partial t} = \nabla \cdot (\tilde{D}\nabla c) + f(c) - G(t)c \text{ in } \Omega \times (0, T], \quad (4)$$

where

$$G(t) = \begin{cases} k, & \text{when chemotherapy is being administered} \\ 0, & \text{otherwise.} \end{cases} \quad (5)$$

Here k describes the rate of cell death due to exposure to the drug. If $f(c) = \rho c$, for a tumor to decrease in size during chemotherapy, k must be larger than the growth rate ρ of the cell population. The main question in this paper is to define k and the periods of chemotherapy applications that lead to control the glioma mass.

In chemotherapy protocols a specific drug or a cocktail of drugs is injected in the circulatory system and are homogeneously distributed in the human body. The effect of chemotherapy in glioma cells is described here by the function $G(t)$ defined by (5). However, the death rate of cells that are exposed to the action of a drug should depend on location, duration of exposure and drug concentration. To incorporate all these interveners in the death rate we need to define a function G depending on $x, t, c(x, t)$ and $c_d(x, t)$. To define such death effect on the tumor cells, the equation for the dynamic of cancer cells needs to be coupled with a diffusion equation for the concentration in the line of the models studied for instance in [Hinow et al.(2009)], [Norris et al.(2006)] and [Ward (2003)], where Michaelis-Menten kinetic or its generalization have been considered in the definition of the corresponding to G . As in the present paper we do not consider such coupling, our assumption on the death rate $G(t)$ while simple, is reasonable and it is mathematically manipulated to allow the definition of chemotherapy protocols with a prescribed effect.

Partial differential equations of non-Fickian type that describe the evolution of cells in a medium where they dye as they move can be establish using the continuous time random walks approach. Without being exhaustive we refer [Abad et al.(2010)], [Fedotov(2010)] and [Sokolov et al.(2006)] where such approach was considered in different contexts. This approach was also considered, for instance in [Fedotov et al.(2007)] and [Fedotov et al.(2008)], to establish non-Fickian diffusion models to describe the proliferation and migration of glioma cells in the absence of the death effect.

Our aim in this paper is the modelling and analysis of glioma growth under the effect of the rheological properties of the brain tissue. The paper is organized as follows. Since the brain tissue presents a viscoelastic behaviour that can be described by a Voigt-Kelvin model (see for instance [Franceschini(2006)], [Humphrey(2003)], [Mehrabian et al.(2011)]), we present in Section 2 a class of non Fickian models to describe the space and time evolution of glioma cancer cells constructed by combining the diffusion process with the viscoelastic properties of the brain tissue. In Section 3 we study the behaviour of the glioma mass when chemotherapy is considered. Criteria to define efficient protocols that lead to the decreasing of the tumor mass are established in this section. In Section 4 we introduce a semi-discrete model that mimics the continuous model in the sense that it presents the same qualitative properties. Plots illustrating the evolution of gliomas are included in

Section 5. The numerical results illustrate the theoretic results obtained. Finally, in Section 6 we present some conclusions. It must be pointed out that the present paper aims to extend the results obtained by the authors in [Branco et al.(2011)], [Branco et al.(2013a)] and [Branco et al.(2013b)].

2. A viscoelastic model

The class of non Fickian models that we present in what follows is established by taking into account the viscoelastic nature of the brain tissue. Following [Edwards et al.(1995a)], [Edwards(1996)], [Edwards(2001)], [Ferreira et al.(2014)], [Liu et al.(2005)] and [Shaw et al.(1997)], if a diffusion process occurs in a medium with a viscoelastic behaviour, then a modified diffusion equation

$$\frac{\partial c}{\partial t} = \nabla \cdot (\tilde{D}\nabla c) + \nabla \cdot (\tilde{D}_v\nabla\sigma) + f(c) \text{ in } \Omega \times (0, \infty), \quad (6)$$

should be used, where σ represents the normal stress which is assumed to be the most relevant component of the stress developed in the brain tissue when the tumor cells move in it. In (6) \tilde{D} and \tilde{D}_v are diffusion and stress drive tensors respectively.

The proliferation and migration of several cancer cells depend on the rigidity of ECM growing significantly better on stiff matrices than on soft tissues ([Tilghman et al.(2010)], [Ulrich et al.(2009)]). This phenomenon is usually called durotaxis or mechanotaxis and it was firstly defined in [Lo et al.(2002)] when the migration of fibroblasts in vitro from soft to stiff regions of the ECM was observed. Based on these facts, \tilde{D}_v in equation (6) is a diagonal tensor with negative entries.

We assume that the viscoelastic behaviour of the brain tissue is described by

$$\frac{\partial\sigma}{\partial t} + \beta\sigma = \alpha_1\epsilon + \alpha_2\frac{\partial\epsilon}{\partial t}, \quad (7)$$

where ϵ stands for the normal strain. Equation (7) is based on a mechanistic model which is represented by a spring (restorative force component) and a dashpot (damping component) in parallel connected with a free spring. In (7) the viscoelastic characteristic time β is given by $\beta = \frac{E_0+E_1}{\mu_1}$, and $\alpha_1 = \frac{E_0E_1}{\mu_1}$, $\alpha_2 = E_0$ where E_1 is the Young modulus of the spring element, μ_1 represents the viscosity and E_0 stands for the Young modulus of the free spring (see

[Franceschini(2006)], [Humphrey(2003)], [Mehrabian et al.(2011)], [Roniotis et al.(2010)].

Equation (7) leads to the following expression for σ

$$\sigma(t) = \int_0^t e^{-\beta(t-s)} (\alpha_1 \epsilon(s) + \alpha_2 \frac{\partial \epsilon}{\partial t}(s)) ds + e^{-\beta t} \sigma(0). \quad (8)$$

If we assume that the strain ϵ satisfies $\epsilon = \lambda c$ where λ is a positive constant (see [Edwards et al.(1995a)], [Edwards(1996)], [Edwards(2001)]), we obtain from (6) and (8) an integro-differential equation

$$\frac{\partial c}{\partial t} = \nabla \cdot (D \nabla c) + \int_0^t k_{er}(t-s) \nabla \cdot (D_v \nabla c(s)) ds + f(c) \text{ in } \Omega \times (0, \infty), \quad (9)$$

where $D = \tilde{D} + \lambda \alpha_2 \tilde{D}_v$, $D_v = \lambda(\alpha_1 - \beta \alpha_2) \tilde{D}_v$ and $k_{er}(s) = e^{-\beta s}$.

In this paper we consider that the viscoelastic behavior of the brain tissue is described by the Voigt-Kelvin model (7) and the mass flux of migration cells J is driven by the gradient of the concentration and by the gradient of the forces exerted by the brain tissue into the glioma cells, that is $J = -\tilde{D} \nabla c - \tilde{D}_v \nabla \sigma$. The stress σ is given by (8) where the strain ϵ is identified with the results of the action of the glioma cells into the brain tissue. Here, to simplify, we assume that such results depend linearly on the glioma cell concentrations. We do not take into account the microenvironment where glioma cells migrate and proliferate, their constituents and their interactions. Mathematical models based on mixture theory and interaction forces between intervenients in the cancer growth have been studied, for instance, in [Astani et al.(2008)], [Byrne et al.(2003)], [Preziosi et al.(2011)], [Preziosi et al.(2009)] and [Sciume et al.(2013)].

To establish a mathematical model to describe the space-time evolution of gliomas some medical information is needed. According to [Fedotov et al.(2007)] and [Fedotov et al.(2008)] the following assumptions are considered in our model: the glioma cells are of two phenotypes - proliferation (state 1) and migratory (state 2); in state 2 (migratory phenotype) the cells randomly move but there is no cell fission; in state 1 (proliferation phenotype) the cancer cells do not migrate and only proliferation takes place with rate ρ ; a cell of type 1 remains in state 1 during a random time period and then switches to a cell of type 2; β_1 is the switching rate from state 1 to 2; a cell of type 2 remains in state 2 during a random time period and then switches to a cell of type 1; β_2 is the switching rate from state 2 to 1.

Let $u(x, t)$ and $v(x, t)$ represent the density of migratory and proliferation cells at x and t , respectively. The dynamics of glioma cells is then described by

$$\begin{cases} \frac{\partial u}{\partial t} = \nabla \cdot (D \nabla u) + \int_0^t k_{er}(t-s) \nabla \cdot (D_v \nabla u(s)) ds - \beta_1 u + \beta_2 v & \text{in } \Omega \times (0, T], \\ \frac{\partial v}{\partial t} = \rho v + \beta_1 u - \beta_2 v & \text{in } \Omega \times (0, T], \end{cases} \quad (10)$$

where $T > 0$ is fixed, D and D_v denote square matrices of order n . The set of equations (10) is complemented with initial conditions

$$u(0) = u_0, v(0) = v_0 \text{ in } \Omega,$$

and boundary conditions

$$J \cdot \eta = 0 \text{ on } \partial\Omega, \quad (11)$$

where $\partial\Omega$ denotes the boundary of Ω , η represents the exterior unit normal and the non Fickian flux J is given by $J(t) = -D \nabla u(t) - \int_0^t e^{-\beta(t-s)} D_v \nabla u(s) ds$. Condition (11) means that the glioma is located inside of the brain and the cancer cells do not cross the pia mater.

In what follows we assume that $D = [d_{ij}]$ and $D_v = [d_{v,ij}]$ are diagonal matrices with diagonal entries d_i and $d_{v,i}$ such that

$$0 < \alpha_0 \leq d_i, d_{v,i} \text{ in } \bar{\Omega}, i = 1, \dots, n. \quad (12)$$

Let $M(t)$ be the mass of glioma cells in Ω , $M_1(t) = \int_{\Omega} (u(t) + v(t)) d\Omega$. We study in what follows the behaviour of $M_1(t)$. We start by remarking that

$$M_1'(t) = \int_{\Omega} \left(\frac{\partial u}{\partial t}(t) + \frac{\partial v}{\partial t}(t) \right) d\Omega. \quad (13)$$

As u and v are defined by the system of equations (10), from (13) we obtain

$$M_1'(t) = \int_{\Omega} (-\nabla \cdot J(t) + \rho v(t)) d\Omega,$$

that leads to

$$M_1'(t) = - \int_{\partial\Omega} J(t) \cdot \eta d\partial\Omega + \rho \int_{\Omega} v(t) d\Omega.$$

From (11) we conclude that $M_1'(t) = \rho \int_{\Omega} v(t) d\Omega$, which means that the instantaneous time variation of the cancer mass depends only as expected on the mass of the proliferation cells and on the proliferation rate ρ . Assuming the positivity of u , we finally obtain the upper bound $M_1(t) \leq e^{\rho t} M_1(0)$.

To avoid the positivity assumption on u we establish in what follows an upper bound for the mass related functional $M_2(t) = \|u(t)\|^2 + \|v(t)\|^2$, where $\|\cdot\|$ denotes the usual L^2 norm induced by the usual L^2 inner product (\cdot, \cdot) . As $M_1(t) \leq \sqrt{|\Omega|} (\|u(t)\| + \|v(t)\|)$, if we assume that $\min\left\{\frac{\|u(t)\|}{\sqrt{|\Omega|}}, \frac{\|v(t)\|}{\sqrt{|\Omega|}}\right\} \geq 1$, we conclude that an upper bound for $M_1(t)$ can be deduced from an estimate of $M_2(t)$. This assumption is biologically sound because it states that the tumor density is largen than 1.

As $\frac{1}{2}M_2'(t) = \left(\frac{\partial u}{\partial t}(t), u(t)\right) + \left(\frac{\partial v}{\partial t}(t), v(t)\right)$, we obtain from (10)

$$\begin{aligned} \frac{1}{2}M_2'(t) &= \int_{\partial\Omega} -J(t) \cdot \eta u(t) d\partial\Omega - \|\sqrt{D}\nabla u(t)\|^2 \\ &\quad - \left(\int_0^t k_{er}(t-s) D_v \nabla u(s) ds, \nabla u(t)\right) \\ &\quad - \beta_1 \|u(t)\|^2 + (-\beta_2 + \rho) \|v(t)\|^2 + (\beta_1 + \beta_2)(u(t), v(t)), \end{aligned} \quad (14)$$

where the inner product in $L^2(\Omega) \times L^2(\Omega)$ is denoted by $((\cdot, \cdot))$ and $\|\cdot\|$ represents the induced norm. Considering the boundary condition (11), the Cauchy-Schwarz inequality and the following equality

$$\begin{aligned} \frac{d}{dt} \left\| \int_0^t k_{er}(t-s) \sqrt{D_v} \nabla u(s) ds \right\|^2 &= 2 \left(\int_0^t k_{er}(t-s) D_v \nabla u(s) ds, \nabla u(t) \right) \\ &\quad - 2\beta \left\| \int_0^t k_{er}(t-s) \sqrt{D_v} \nabla u(s) ds \right\|^2, \end{aligned} \quad (15)$$

we deduce from (14) that

$$E'(t) \leq \max\{\beta_2 - \beta_1, \beta_1 - \beta_2 + 2\rho, -2\beta\} E(t), t > 0, \quad (16)$$

where $E(t) = M_2(t) + \left\| \int_0^t k_{er}(t-s) \sqrt{D_v} \nabla u(s) ds \right\|^2$. Inequality (16) leads to

$$M_2(t) \leq e^{2 \max\{\frac{\beta_2 - \beta_1}{2}, \frac{\beta_1 - \beta_2}{2} + \rho, -\beta\}t} M_2(0). \quad (17)$$

We observe that if $\max\{\beta_2 - \beta_1, \beta_1 - \beta_2 + 2\rho, -2\beta\} = -2\beta$ then $\beta_1 + 2\rho + 2\beta < \beta_2 < \beta_1 - 2\beta$ which is not possible. This means that we can drop -2β from the max expression. In the case $\beta_2 - \beta_1 > \beta_1 - \beta_2 + 2\rho$ we have $\beta_2 - \beta_1 > \rho$; for $\beta_2 < \beta_1 + \rho$ the maximum is $2\rho - \beta_2 + \beta_1 > \rho$. In both cases the second member of (17) is an increasing function of t . As expected, under these assumptions, we can not select parameters β_2, β_1, ρ such that $M_2(t)$ is bounded in time.

We remark that inequality (17) allow us to conclude the stability of the proposed mathematical model with respect to perturbations of the initial conditions in $[0, T]$, for fixed $T > 0$.

3. Chemotherapy : control of the glioma growth

To take into account the chemotherapy effect, the viscoelastic model for glioma growth (10) is modified as follows

$$\begin{cases} \frac{\partial u}{\partial t} = \nabla \cdot (D \nabla u) + \int_0^t k_{er}(t-s) \nabla \cdot (D_v \nabla u(s)) ds \\ -\beta_1 u + \beta_2 v - G(t)u \text{ in } \Omega \times (0, T], \\ \frac{\partial v}{\partial t} = \rho v + \beta_1 u - \beta_2 v - G(t)v \text{ in } \Omega \times (0, T], \end{cases} \quad (18)$$

where $G(t)$ is defined by (5).

From (18) following the proof of the upper bound (16), it can be shown that

$$E'(t) \leq 2 \max\left\{ \frac{\beta_2 - \beta_1}{2} - G(t), \frac{\beta_1 - \beta_2}{2} + \rho - G(t), -\beta \right\} E(t). \quad (19)$$

In what follows we establish conditions on the parameters that lead to a decreasing of $M_2(t)$:

- (1) If the net proliferation rate is greater than the switching proliferation rate

$$\rho > \beta_2 - \beta_1, \quad (20)$$

and the difference between the rate of cells death and the switching proliferation rate is bounded by the viscoelastic characteristic time

$$G(t) - \frac{\beta_2 - \beta_1}{2} < \beta, \quad (21)$$

then equation (19) leads to

$$M_2(t) \leq e^{2\left(\left(\frac{\beta_1 - \beta_2}{2} + \rho\right)t - \int_0^t G(s) ds\right)} M_2(0). \quad (22)$$

To conclude that $M_2(t)$ decreases we need to combine condition (20) and (21) with

$$\left(\frac{\beta_1 - \beta_2}{2} + \rho\right)t < \int_0^t G(s) ds, \quad (23)$$

that is the density of proliferation cells at time t is less than the total amount of death cells until time t due to chemotherapy effect.

As from condition (21) we obtain

$$\int_0^t G(s) ds < \left(\frac{\beta_2 - \beta_1}{2} + \beta\right)t, \quad (24)$$

conditions (23) and (24) are compatible if the difference between the net and switching proliferation rates is less than the viscoelastic characteristic time

$$\rho - (\beta_2 - \beta_1) < \beta. \quad (25)$$

If no viscoelastic effects are considered, $\beta = 0$, we deduce from (24) that an overall admissible measure of the treatment , $\int_0^t G(s) ds$, should be smaller.

- (2) Otherwise, if the net proliferation rate is less than the switching proliferation rate

$$\rho < \beta_2 - \beta_1 \quad (26)$$

and the difference between the rate of cells death and the resident proliferation rate is bounded by the viscoelastic characteristic time

$$G(t) - \left(\rho - \frac{\beta_2 - \beta_1}{2}\right) < \beta, \quad (27)$$

then inequality (22) is replaced by

$$M_2(t) \leq e^{2\left(\left(\frac{\beta_2 - \beta_1}{2} - \rho\right)t - \int_0^t G(s) ds\right)} M_2(0). \quad (28)$$

Assuming that the density of switching proliferation cells at time t is less than the total amount of death cells until time t due to chemotherapy effect

$$\left(\frac{\beta_2 - \beta_1}{2}\right)t < \int_0^t G(s) ds, \quad (29)$$

we conclude that $M_2(t)$ decreases. Again we observe that the parameter β has influence on the admissible threshold of the chemotherapy treatment.

We note that as from (27)

$$\left(\frac{\beta_1 - \beta_2}{2} + \rho + \beta\right)t > \int_0^t G(s) ds, \quad (30)$$

we must impose that the difference between the net and switching proliferation rates is greater than the viscoelastic characteristic time

$$\rho - (\beta_2 - \beta_1) > \beta \quad (31)$$

in order to have the compatibility between (29) and (30).

When chemotherapy is applied, conditions (21) and (23) or conditions (27) and (29) can be used to determine an effective dosage that induces a rate k of cell death due to the exposure to the drug that allows to control the total tumor mass. Obviously the value of k depends of the protocol of chemotherapy. The typical bang-bang protocol corresponds to treatment which alternate maximum doses of chemotherapy with rest periods when no drug is administered, as defined by (5) and illustrated in Figure 1.

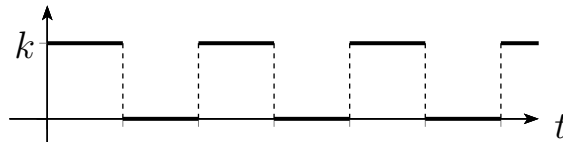

Figure 1: Chemotherapy protocol.

4. A semi-discrete model

To compute the artificial mass $M_2(t)$ we use a numerical method which is obtained discretizing the spatial derivatives of (18) using centered difference operators. In what follows we show that this discretization preserves the qualitative behaviour of the initial boundary value problem studied in the last section. More precisely we establish the discrete versions of the inequalities

(22) and (28) under the conditions (20), (21), (23), (25) or (26), (27), (29), (31), respectively.

We assume that $n = 2$, Ω is the square $[0, L] \times [0, L]$ and $H = (h_1, h_2)$ with $h_i > 0, i = 1, 2$. In $\bar{\Omega}$ we introduce the spatial grid $\bar{\Omega}_H = \{(x_{1,i}, x_{2,j}), i = 0, \dots, N_{h_1}, j = 0, \dots, N_{h_2}\}$, where $x_{\ell,i} = x_{\ell,i-1} + h_\ell, i = 1, \dots, N_{h_\ell}, x_{\ell,0} = 0, x_{\ell,N_{h_\ell}} = L$, for $\ell = 1, 2$. By $\partial\Omega_H$ we represent the set of boundary points. We introduce the following auxiliary points $x_{\ell,-1} = x_{\ell,0} - h_\ell, x_{\ell,N_{h_\ell}+1} = x_{\ell,N_{h_\ell}} + h_\ell, \ell = 1, 2$.

To simplify the presentation we use the notation $w_{i,j} = w_H(x_{1,i}, x_{2,j})$. We discretize $\frac{\partial}{\partial x_1}(a \frac{\partial u}{\partial x_1})$, a is a scalar functions, using the usual second order finite difference discretization

$$\nabla_{h_1}^* (\hat{a}_H \nabla_{h_1} u_H)(x_{1,i}, x_{2,j}) = \frac{1}{h_1} (a_{i+1/2,j} D_{-x_1} u_{i+1,j} - a_{i-1/2,j} D_{-x_1} u_{i,j}), \quad (32)$$

where $a_{i\pm 1/2,j} = a(x_{1,i} \pm \frac{h_1}{2}, x_{2,j})$ and D_{-x_1} denotes the usual backward finite difference operator in x_1 direction. The second order finite difference discretization $\nabla_{h_2}^* (\hat{b}_H \nabla_{h_2} u_H)(x_{1,i}, x_{2,j})$ to discretize $\frac{\partial}{\partial x_2}(b \frac{\partial u}{\partial x_2})$ is defined analogously.

The semi-discrete approximation for u and v in $\bar{\Omega}_H$ at time t , $u_H(t)$ and $v_H(t)$, are defined by the following system of ordinary differential equations

$$\begin{cases} u'_H(t) = \sum_{i=1,2} \nabla_{h_i}^* (d_i \nabla_{h_i} u_H(t)) + \int_0^t k_{er}(t-s) \sum_{i=1,2} \nabla_{h_i}^* (d_{v,i} \nabla_{h_i} u_H(s)) ds \\ \quad - (\beta_1 + G(t)) u_H(t) + \beta_2 v_H(t) \quad \text{in } \bar{\Omega}_H, \\ v'_H(t) = (\rho - \beta_2 - G(t)) v_H(t) + \beta_1 u_H(t) \quad \text{in } \bar{\Omega}_H, \end{cases} \quad (33)$$

complemented with the initial conditions

$$u_H(0) = R_H u_0, \quad v_H(0) = R_H v_0 \quad \text{in } \bar{\Omega}_H, \quad (34)$$

and the boundary conditions

$$\begin{aligned} D_{\eta_{x_1}} u_{i,j}(t) &= 0, \quad i = 0, N_{h_1}, j = 0, \dots, N_{h_2}, \\ D_{\eta_{x_2}} u_{i,j}(t) &= 0, \quad i = 0, \dots, N_{h_1}, j = 0, N_{h_2}, \end{aligned} \quad (35)$$

where, for $m = 1, 2$,

$$D_{\eta_{x_m}} u_{i,j}(t) = D_{d,\eta_{x_m}} u_{i,j}(t) + \int_0^t k_{er}(t-s) D_{v,\eta_{x_m}} u_{i,j}(s) ds, \quad (36)$$

In (34) R_H denotes the restriction operator and in (36) $D_{a,\eta_{x_1}}$ is defined by

$$D_{a,\eta_{x_1}} w_{i,j} = \frac{1}{2} \left(a_{i+1/2,j} D_{-x_1} w_{i+1,j} + a_{i-1/2,j} D_{-x_1} w_{i,j} \right),$$

being $D_{b,\eta_{x_2}} w_{i,j}$ defined analogously.

To prove a discrete version of the upper bounds (22), (28) we follow [Ferreira et al.(2012)] to introduce a convenient discrete functional context. By $W_H(\overline{\Omega}_H)$ we denote the space of grid functions defined in $\overline{\Omega}_H$. In $W_H(\overline{\Omega}_H)$ we introduce the inner product

$$(w_H, q_H)_{\overline{\Omega}_H} = \sum_{i=0}^{N_{h_1}} \sum_{j=0}^{N_{h_2}} \omega_{i,j} w_{i,j} q_{i,j}, \quad w_H, q_H \in W_H(\overline{\Omega}_H), \quad (37)$$

where $\omega_{i,j} = h_1 h_2$ in Ω_H , $\omega_{i,j} = \frac{1}{2} h_1 h_2$ on $\partial\Omega_H - \mathcal{C}_H$, $\omega_{i,j} = \frac{1}{4} h_1 h_2$ on \mathcal{C}_H , \mathcal{C}_H denotes the set of corner points of $\overline{\Omega}$ and $\partial\Omega_H = \overline{\Omega}_H \cap \partial\Omega$. The norm induced by the inner product (37) is denoted by $\|\cdot\|_H$.

To simplify the presentation we use the following notations:

$$(w_H, q_H)_{\partial\Omega_H, x_1} = \sum_{i=0, N_{h_1}} \left(\sum_{j=1}^{N_{h_2}-1} h_2 w_{i,j} q_{i,j} + \sum_{j=0, N_{h_2}} \frac{1}{2} h_2 w_{i,j} q_{i,j} \right),$$

for grid functions defined on $\partial\Omega_H$, being $(w_H, q_H)_{\partial\Omega_H, x_2}$ defined analogously, and for $w_H, q_H \in W_H(\overline{\Omega}_H)$

$$(w_H, q_H)_{h_1} = \sum_{i=1}^{N_{h_1}} h_1 \left(\sum_{j=1}^{N_{h_2}-1} h_2 w_{i,j} q_{i,j} + \sum_{j=0, N_{h_2}} \frac{h_2}{2} w_{i,j} q_{i,j} \right),$$

being $(w_H, q_H)_{h_2}$ defined analogously,

$$\|w_H\|_H^2 = (w_H, w_H)_{\overline{\Omega}_H}, \quad \|w_H\|_{1,s}^2 = \sum_{i=1,2} \|D_{-x_i} w_H\|_{h_i}^2.$$

The following identity has a central role in what follows and it can be shown using summation by parts

$$\begin{aligned} (\nabla_{h_\ell}^*(a_\ell \nabla_{h_\ell} w_H), w_H)_{\overline{\Omega}_H} &= -(\hat{a}_{\ell,H} D_{-x_\ell} w_H, D_{-x_\ell} w_H)_{h_\ell} \\ &+ (D_{a_\ell, \eta_{x_\ell}} w_H \eta_{x_\ell}, w_H)_{\partial\Omega_{H,x_\ell}}, \quad \ell = 1, 2. \end{aligned} \quad (38)$$

In what follows we establish an upper bound for the semi-discrete version of $M_2(t)$

$$M_{2,H}(t) = \|u_H(t)\|_H^2 + \|v_H(t)\|_H^2,$$

where $u_H(t)$ and $v_H(t)$ are defined by (33), (34) and (35). Let $E_H(t)$ be the semi-discrete version of $E(t)$

$$E_H(t) = M_{2,H}(t) + \sum_{i=1,2} \left\| \int_0^t k_{er}(t-s) \sqrt{\hat{d}_{v,i,H}} D_{-x_i} u_H(s) ds \right\|_{h_i}^2.$$

Multiplying both equations of (33) by $u_H(t)$ and $v_H(t)$, respectively, with respect to the inner product $(\cdot, \cdot)_{\overline{\Omega}_H}$ and taking into account (38) we deduce

$$\begin{aligned} \frac{d}{dt} \|u_H(t)\|_H^2 &= - \sum_{i=1,2} (\hat{d}_{i,H} D_{-x_i} u_H(t), D_{-x_i} u_H(t))_{h_i} \\ &\quad - (\beta_1 + G(t)) \|u_H(t)\|_H^2 + \beta_2 (v_H(t), u_H(t))_{\overline{\Omega}_H} \\ &\quad - \int_0^t k_{er}(t-s) \sum_{i=1,2} (\hat{d}_{v,i,H} D_{-x_i} u_H(s), D_{-x_i} u_H(t))_{h_i} ds \\ &\quad + \sum_{i=1,2} (D_{\eta_{x_i}} u_H(t) \eta_{x_i}, u_H(t))_{\partial\Omega_{x_i}} \end{aligned} \quad (39)$$

and

$$\frac{d}{dt} \|v_H(t)\|_H^2 = (\rho - \beta_2 - G(t)) \|v_H(t)\|_H^2 + \beta_1 (u_H(t), v_H(t))_{\overline{\Omega}_H}. \quad (40)$$

Considering the boundary conditions (35), the discrete version of (15)

$$\begin{aligned} \frac{d}{dt} \left\| \int_0^t k_{er}(t-s) \sqrt{\hat{d}_{v,i,H}} D_{-x_i} u_H(s) ds \right\|_{h_i}^2 \\ &= 2 \left(\int_0^t k_{er}(t-s) \hat{d}_{v,i,H} D_{x_i} u_H(s) ds, D_{-x_i} u_H(t) \right)_{h_i} \\ &\quad - 2\beta \left\| \int_0^t k_{er}(t-s) \sqrt{\hat{d}_{v,i,H}} D_{-x_i} u_H(s) ds \right\|_{h_i}^2, \end{aligned}$$

and the Cauchy-Schwarz inequality, from (39), (40) we get

$$E'_H(t) \leq 2 \max \left\{ \frac{\beta_2 - \beta_1}{2} - G(t), \frac{\beta_1 - \beta_2}{2} + \rho - G(t), -\beta \right\} E_H(t), \quad (41)$$

If (20) and (21) then

$$M_{2,H}(t) \leq e^{2\left(\left(\frac{\beta_1 - \beta_2}{2} + \rho\right)t - \int_0^t G(s) ds\right)} M_{2,H}(0) \quad (42)$$

Otherwise, if (26) and (27) then

$$M_{2,H}(t) \leq e^{2\left(\frac{\beta_2 - \beta_1}{2}t - \int_0^t G(s) ds\right)} M_{2,H}(0), \quad (43)$$

Finally, if (20), (21), (23) and (25) or (26), (27), (29) and (31), then the discrete artificial mass $M_{2,H}(t)$ is bounded by $M_{2,H}(0)$. In the first case the decreasing factor is $e^{2\left(\left(\frac{\beta_1 - \beta_2}{2} + \rho\right)t - \int_0^t G(s) ds\right)}$ and $e^{2\left(\frac{\beta_2 - \beta_1}{2}t - \int_0^t G(s) ds\right)}$ in the second case.

5. Results

In this section we present some numerical results illustrating the behaviour of the glioma cells defined by (33), (34) and (35). The numerical results were obtained integrating in time the ordinary differential problem using the implicit Euler method and discretizing the integral term in (33) with a left rectangular rule. We consider a homogeneous square domain $\Omega = [0, 15 \text{ cm}] \times [0, 15 \text{ cm}]$, growth rate $\rho = 0.012 / \text{day}$ and switching parameters $\beta_1 = 10^{-6} / \text{day}$ and $\beta_2 = 0.036 / \text{day}$. These parameters were obtained from [Roniotis et al.(2010)] and have biological meaning. According to [Mehraban et al.(2011)], the initial condition is defined by 10^5 cells/cm^2 of proliferation tumor cells at middle point of the domain, $E_0 = 3156 \text{ Pa}$, $E_1 = 6E_0$ and $\mu = 8.9 \times 10^{-4} \text{ Pa} \cdot \text{s}$. We also consider $\lambda = 1 \text{ cm}^2$, isotropic behaviour with $\tilde{d}_{11} = \tilde{d}_{22} = 0.004 \text{ cm}^2 / \text{day}^2$ and to guarantee the positivity of D_v we take $\tilde{d}_{v,11} = \tilde{d}_{v,22} = -10^{-14} \text{ cell/Pa day}$ ([Kee et al.(2005)], [Liu et al.(2005)]) which leads to $d_{11} = d_{22} \sim 0.004 \text{ cm}^2 / \text{day}$ and $d_{v,11} = d_{v,22} = 0.001 \text{ cm}^2 / \text{day}^2$.

In Figure 2 we plot the numerical solution at day 6. Solution is presented in logarithmic scale, which means that contour plots represent the power of 10 of the density of tumor cells. In this case we observe a very intense spreading of proliferation cells and we can conclude that migration cells are already quite far from the core.

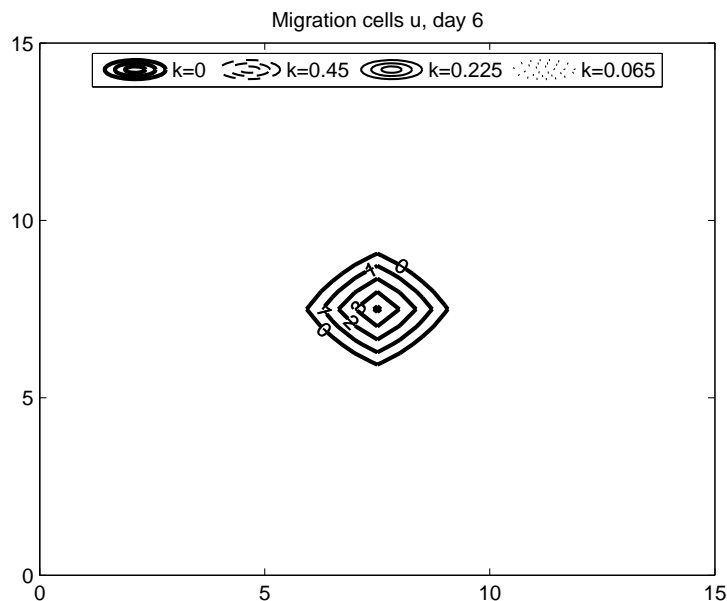

Figure 2: Numerical results at day 6 (logarithmic scale).

Let us consider now that the chemotherapy treatment defined by (5) is applied with a protocol as illustrated in Figure 1. Conditions (21) and (23) are used to compute a profile for $G(t)$ that lead to control the total tumor mass. We consider a 24h dosage and different rest periods. In Table 1 we show the minimum value of k ((5)) defined by conditions (21) and (23), for a virtual patient as defined in the beginning of this section.

Protocol	k_{\min} [./day]
each 2 days	0.064
each 7 days	0.224
each 14 days	0.448

Table 1: k_{\min} as (21) and (23), for a protocol of 24 consecutive hours of chemotherapy.

In Figure 3 we plot cell distribution at day 104 for an untreated patient and three patients with different chemotherapy protocols. All three protocols start at day 7, and follow different rest periods represented in Figure 1 ($k = 0.065/day$ is associated to a 24h dosage at days 7, 9, 11, 13, etc; $k = 0.225/day$ is associated to a 24h dosage at days 7, 14, 21, 28, etc; $k = 0.45/day$ is associated to a 24h dosage at days 7, 21, 35, 49, etc). We observe that glioma mass density is significantly reduced when chemotherapy is used, although we do not observe a significant reduction of the tumor's

area. We remind that all plots are presented using logarithmic scale of the density of cells.

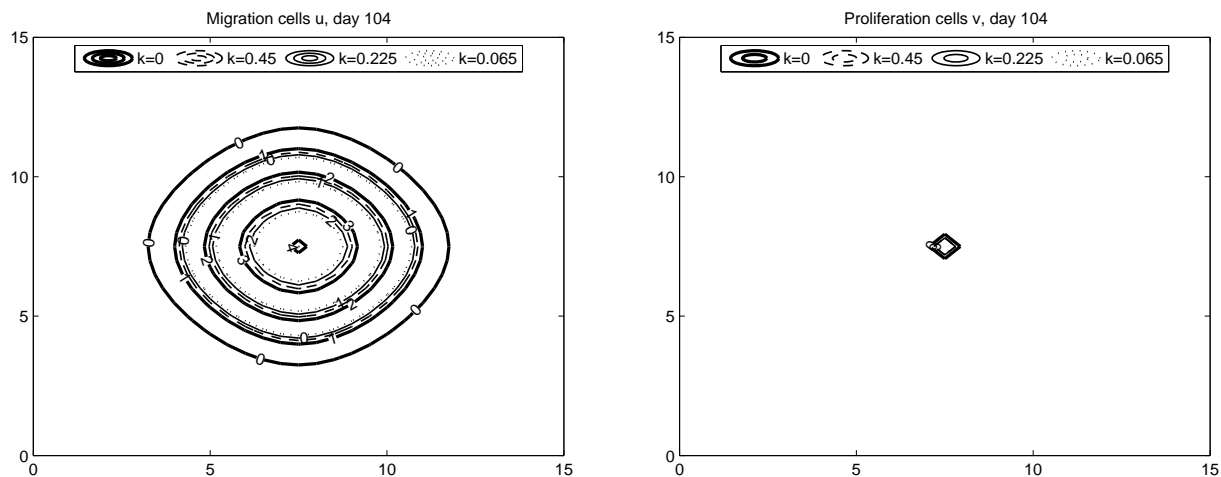

Figure 3: Numerical results at day 104 (logarithmic scale).

Finally, in Figure 4 we compare glioma masses of the virtual patient when no chemotherapy is administered and the results of the administration of the above three chemotherapy protocols. We observe a significant reduction of glioma masses when compared to glioma's untreated patient. The results presented in this figure shows the effectiveness of the our approach to define chemotherapy protocols.

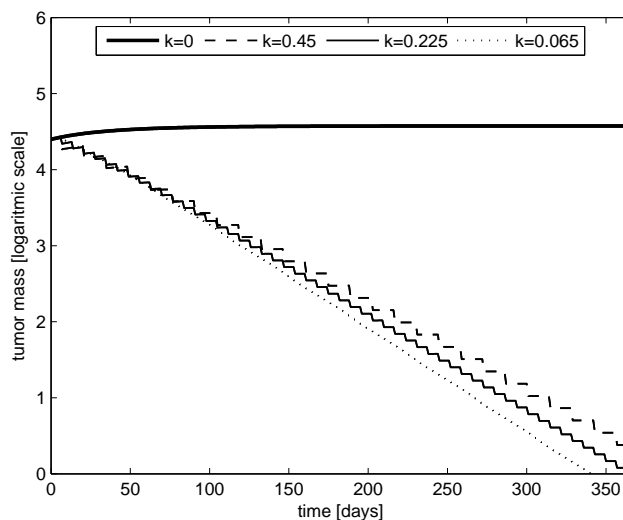

Figure 4: Glioma masses $M_1(t)$ for 1 year (logarithmic scale).

6. Conclusions

In this paper we studied a mathematical model to describe the evolution of glioma cells with and without chemotherapy. The model was established combining a mass conservation law with a non Fickian mass flux that takes into account the viscoelastic behaviour of the brain tissue described by the Voigt-Kelvin model.

Using the energy method we deduced estimates for a functional related glioma mass $M_2(t)$ defined using L^2 norm. These estimates allowed us to define sufficient conditions on the parameters that lead to the control of $M_2(t)$.

Semi-discrete approximations for the proliferation and migratory cancer cells presenting the same qualitative behaviour of the continuous counterparts were introduced. Sufficient conditions that relate the chemotherapy effect with the growing rates of the semi-discrete migratory and proliferations glioma cells that lead to $M_{2,H}(t) < M_{2,H}(0)$ were also established. These conditions allow us to define efficient protocols that lead to a decreasing of the cancer mass.

Numerical experiments illustrating the behaviour of the glioma mass under the conditions deduced for the chemotherapy protocols are also included. The results obtained suggest that our approach is a promising one.

Models that will take into account the space effect of chemotherapy will be addressed in a future work. In this case we need to incorporate in the diffusion equation for the drug concentration the viscoelastic effect of the brain tissue on the diffusion drug similar to the one considered here in the migration of glioma cells. As the complete model is composed by integro-differential quasilinear equations of diffusion-reaction type, its mathematical and numerical study is a challenging problem. Future work will also address mathematical models with a real geometry and that takes into account the white and gray matter of the brain. Comparison of the model with existing medical protocols will be also considered.

7. Acknowledgements

This work was partially supported by the Centro de de Matemática da Universidade de Coimbra (CMUC), funded by the European Regional Development Fund through the program COMPETE and by the Portuguese Government through the FCT - Fundação para a Ciência e Tecnologia under the projects PEst-C/MAT/UI0324/2013.

References

- [Abad et al.(2010)] E. Abad, S. Yuste, K. Lindenberg, Reaction-subdiffusion and reaction-superdiffusion equations for evanescent particles performing continuous time random walks, *Physical Reviews* 81 (2010), 031115:1–7.
- [Astani et al.(2008)] S. Astani, L. Preziosi, Multiphase models of tumor cells, in *Selected Topics in Cancer Modeling: Genesis, Evolution, Immune Competition, and Therapy*, Editors: N. Bellomo, M. Chaplain, E. De Angelis, Birkhauser (2008) 223–253.
- [Byrne et al.(2003)] H. Byrne, J. R. King, D. McElwain, A two-phase model of solid tumor growth, *Applied Mathematics Letters* 16 (2003) 567–573.
- [Branco et al.(2011)] J. R. Branco, J. A. Ferreira, P. de Oliveira, Memory in mathematical modelling of highly diffusive tumors, in *Proceedings of the 2011 International Conference on Computational and mathematical Methods in Science and Engineering*, Benidorm, Spain, June 26-30, 2011, Editor: J. Vigo Aguiar (2011) 242–253.
- [Branco et al.(2013a)] J. R. Branco, J. A. Ferreira, P. de Oliveira, Efficient protocols to control glioma growth, in *Proceedings of the 2013 International Conference on Computational and mathematical Methods in Science and Engineering*, Almeria, Spain, June 24-27, 2013, Editors: I. Hamilton and J. Vigo-Aguiar (2013) 293–303.
- [Branco et al.(2013b)] J. R. Branco, J. A. Ferreira, P. Oliveira, A viscoelastic model for glioma growth, with J.R. Branco, in *Proceedings of SIMULTECH 2013- 3rd International Conference on Simulation and Modeling, Technologies and Applications, Methodologies*, Reykjavik, Iceland, 29-31 July, 2013, Editors: Tuncer Ȧren, Janusz Kacprzyk, Leifur Leifsson, Mohammad S. Obaidat and Slawomir Koziel (2013) 689–695.
- [Kee et al.(2005)] D. De Kee, Q. Liu and J. Hinestroza, Viscoelastic (non-Fickian) diffusion, *The Canadian Journal of Chemical Engineering* 83 (2005) 913–929.
- [Edwards et al.(1995a)] D. A. Edwards, D. S. Cohen, An unusual moving boundary condition arising in anomalous diffusion problems, *SIAM Journal on Applied Mathematics* 55 (1995) 662–676.
- [Edwards et al.(1995b)] D. A. Edwards, D. S. Cohen, A mathematical model for a dissolving polymer, *AIChE Journal* 41 (1995) 2345–2355.
- [Edwards(1996)] D. A. Edwards, Non-Fickian diffusion in thin polymer films, *Journal of Polymer Science, Part B: Polymer Physics Edition* 34 (1996) 981–997.
- [Edwards(2001)] D. A. Edwards, A spatially nonlocal model for polymer-penetrant diffusion, *Journal of Applied Mathematics and Physics* 52 (2001) 254–288.
- [Engler et al.(2006)] A. Engler, S. Sen H. Sweeney, D. Discher, Matrix elasticity directs stem cell lineage specification, *Cell* 126 (2006) 677–689.
- [Engler et al.(2007)] A. Engler, H. Sweeney, D. Discher, J. Schwarzbauer, Extracellular matrix elasticity directs stem cell differentiation, *Journal of Musculoskeletal and Neuronal Interactions* 7 (2007) 335.
- [Fedotov(1998)] S. Fedotov, Traveling waves in a reaction-diffusion system: diffusion with finite velocity and Kolmogorov-Petrovskii-Piskunov kinetics, *Physical Review E* 58 (1998) 4:5143–5145.
- [Fedotov(1999)] S. Fedotov, Nonuniform reaction rate distribution for the generalized Fisher equation: Ignition ahead of the reaction front, *Physical Review E* 60 (1999) 4:4958–4961.
- [Fedotov et al.(2007)] S. Fedotov, A. Iomin, Migration and proliferation dichotomy in tumor-cell invasion, *Physical Review Letters* 98 (2007) 118110(1)–(4).
- [Fedotov et al.(2008)] S. Fedotov, A. Iomin, Probabilistic approach to a proliferation and migration dichotomy in tumor cell invasion, *Physical Review E* 77 (2008) 1031911(1)–(10).

- [Fedotov(2010)] S. Fedotov, Non-Markovian random walks and nonlinear reactions: subdiffusion and propagation fronts, *Physical Review E* 81 (2010) 011117:1–7.
- [Ferreira et al.(2012)] J.A. Ferreira, P. de Oliveira, P. Silva, Reaction-diffusion in viscoelastic materials, *Journal of Computational and Applied Mathematics* 236 (2012) 3783–3795.
- [Ferreira et al.(2014)] J.A. Ferreira, M. Grassi, E. Gudiño, P. de Oliveira, A 3D model for mechanistic control drug release, *SIAM Journal on Applied Mathematics* 74 (2014) 620–633.
- [Franceschini(2006)] G. Franceschini, The mechanics of human brain tissue, PhD thesis, University of Trento, 2006.
- [Giese et al.(1996)] A. Giese, L. Kluwe, B. Laube, H. Meissner, M. Berens, M. Westphal, Migration of human glioma cells on myelin, *Neurosurgery* 38 (1996) 755–764.
- [Habib et al.(2003)] S. Habib, C. Molina-París, T. Deisboeck, Complex dynamics of tumors: modeling an emerging brain tumor system with coupled reaction-diffusion equations, *Physica A* 327 (2003) 501–524.
- [Hassanizadeh(1996)] S. Hassanizadeh, On the transient non-Fickian dispersion theory, *Transport in Porous Media* 23 (1996) 107–124.
- [Harpold et al.(2007)] H. L. Harpold, E. C. Alvord Jr, K. R. Swanson, The evolution of mathematical modeling of glioma proliferation and invasion, *Journal of Neuropathology and Experimental Neurology* 66 (2007) 1–9.
- [Hinow et al.(2009)] P. Hinow, P. Gerlee, L. McCawley, V. Quaranta, M. Cionanu, S. Wang, J. Graham, B. Ayati, J. Claridge, K. Swanson, M. Loveless, A. Anderson, A spatial model of tumor host interaction: application of chemotherapy, *Mathematical Biosciences and Engineering* 6 (2009) 521–545.
- [Humphrey(2003)] J. Humphrey, Continuum biomechanics of soft biological tissues, *Proceedings of Royal Society London* 459 (2003) 3–46.
- [Joseph et al.(1989)] D. Joseph, L. Preziosi, Heat waves, *Review of Modern Physics* 61 (1989) 47–71.
- [Laperriere et al.(2002)] N. Laperriere, L. Zurawb, G. Cairncross, The Cancer Care Ontario Practice Guidelines Initiative Neuro-Oncology Disease Site Group, Radiotherapy for newly diagnosed malignant glioma in adults: a systematic review, *Radiotherapy and Oncology* 64 (2002) 259–273.
- [Liu et al.(2005)] Q. Liu, X. Wang, D. De Kee, Mass transport through swelling membranes, *International Journal of Engineering Science* 43 (2005) 1464–1470.
- [Lo et al.(2002)] C. Lo, H. Wang, M. Dembo, Y. Wang, Cell movement in guided by the rigidity of the substrate, *Biophysics Journal* 79 (2000) 144–152.
- [Mehrabian et al.(2011)] A. Mehrabian, Y. Abousleiman, General solutions to poroviscoelastic model of hydrocephalic human brain tissue, *Journal of Theoretical Biology* 291 (2011) 105–118.
- [Murray(2002)] J. D. Murray, *Mathematical Biology*, Springer, 2002.
- [Neuman(2009)] S. P. Neuman, D. M. Tartakovsky, Perspective on theories of anomalous transport in heterogeneous media, *Advances in Water Resources* 32 (2009) 670–680.
- [Norris et al.(2006)] E. Norris, J. King, M. Byrne, Modelling the response of spatial structured tumours to chemotherapy: drug kinetics, *Mathematical and Computer Modelling* 43 (2006) 820–837.
- [Preziosi et al.(2009)] L. Preziosi, A. Tosin, Multiphase modelling of tumor growth and extracellular matrix interaction: mathematical tools and applications, *Journal of Mathematical Biology* 58 (2009) 625–656.
- [Preziosi et al.(2011)] L. Preziosi, G. Vitale, A multiphase model of tumour and tissue growth including cell adhesion and plastic re-organisation, *Mathematical Models and Methods in Applied Sciences* 21 (2011) 1901–1932.

- [Rockne et al.(2009)] R. Rockne, E. C. Alvord Jr, J. K. Rockhill, K. R. Swanson, A mathematical model for brain tumor response to radiation therapy, *Journal of Mathematical Biology* 58 (2009) 561–578.
- [Roniotis et al.(2010)] A. Roniotis, K. Marias, V. Sakkalis, M. Zervakis, Diffusive modelling of glioma evolution: a review, *J. Biomedical Science and Engineering* 3 (2010) 501–508.
- [Sciume et al.(2013)] G. Sciumè, S.Shelton, W. Gray, C. Miller, F.Hussain, M. Ferrari, P. Decuzzi, B. Schrefler, A multiphase model for three-dimensional tumor growth, *New Journal of Physics*, 15 (2013) 015005.
- [Shaw et al.(1997)] S. Shaw, J. R. Whiteman, Some partial differential Volterra equation problems arising in viscoelasticity, *Proceeding of the Conference on Differential Equations and their Applications*, Brno, (1997) 183–200.
- [Sokolov et al.(2006)] I. Sokolov, M. Schmidt, F. Sagués, On reaction-subdiffusion equations, *Physical Review E* 73 (2006) 031102.
- [Swanson et al.(2000)] K. R. Swanson, E.C. Alvord Jr, J.D. Murray, A quantitative model for differential motility of gliomas in grey and white matter, *Cell Proliferation* 33 (2000) 317–329.
- [Swanson et al.(2003)] K. R. Swanson, C. Bridge, J. D. Murray, E. C. Alvord Jr, Virtual and real brain tumors: using mathematical modelig to quantify glioma growth and invasion, *Journal of the Neurological Sciences* 216 (2003) 1–10.
- [Tilghman et al.(2010)] R. Tilghman, C. Cowan, J. Mih, Y. Koryakina, D. Gioli, J. Slack-Davis, B. Blackman, D. Tschumperlin, J. Parsons, Matrix rigidity regulates cancer cell growth and cellular phenotype, *PloS One* 5 (2010), e12905.
- [Tracqui et al.(1995)] P. Tracqui, G. C. Cruywagen, D. E. Woodward, G. T. Bartoo, J. D. Murray, E. C. Alvord Jr, A mathematical model of glioma growth: the effect of chemotherapy on spatio-temporal growth, *Cell Proliferation* 28 (1995) 17–31.
- [Ulrich et al.(2009)] T. A. Ulrich, E. M. de Juan Pardo, S. Kumar, The mechanical rigidity of the extracellular matrix regulates the structure, motility, and proliferation of Glioma Cells, *Cancer Research* 69 (2009) 4167–4174.
- [Ward (2003)] J. Ward, J.King, Mathematical modelling of drug transport in tumour multicell spheroids and monolayer cultures, *Mathematical Biosciences* 181 (2003) 177–207.

J.R. BRANCO

CMUC, DEPARTAMENTO DE FÍSICA E MATEMÁTICA, INSTITUTO SUPERIOR DE ENGENHARIA DE COIMBRA, RUA PEDRO NUNES-QUINTA DA NORA, 3030-199 COIMBRA, PORTUGAL.

E-mail address: jrbranco@isec.pt

J.A. FERREIRA

CMUC, DEPARTMENT OF MATHEMATICS, UNIVERSITY OF COIMBRA, APARTADO 3008, EC SANTA CRUZ, 3001-501 COIMBRA, PORTUGAL

E-mail address: ferreira@mat.uc.pt

URL: <http://www.mat.uc.pt/~ferreira>

P. DE OLIVEIRA

CMUC, DEPARTMENT OF MATHEMATICS, UNIVERSITY OF COIMBRA, APARTADO 3008, EC SANTA CRUZ, 3001-501 COIMBRA, PORTUGAL

E-mail address: poliveir@mat.uc.pt

URL: <http://www.mat.uc.pt/~poliveir>